

# DIGITAL COUNTER

BERETTA 92 FS



## PACKAGE CONTENTS



DIGITALCOUNTER x1

Plastic support x1

Follower x2

## TOOLS

\*not included



Screwdriver

CR 2016 Battery x2

## ASSEMBLY - GUN

Disassemble the original grips

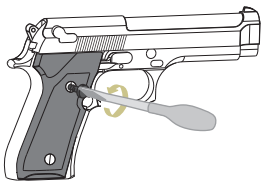

Assemble the batteries (Left Grip)

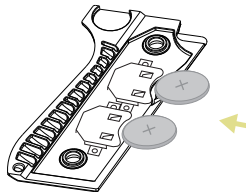

Assemble plastic support

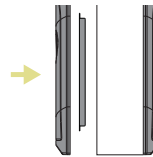

Put the plastic support between the gun and the left grip.

Assemble DIGITALCOUNTER grips using original screws & washers

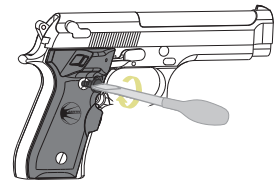

### WARNING

Always make sure your firearm is unloaded, no rounds in the chamber and pointed in a safe direction before you disassemble and work on it.

### WARNING

This device DOES NOT count rounds in the chamber and DOES NOT show if there is a round in the chamber. Always make sure your firearm is unloaded and with no round in the chamber.

## ASSEMBLY - MAGAZINE Use only Beretta original magazines.

Disassemble the magazine

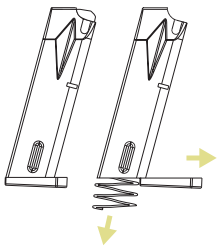

Remove the original follower

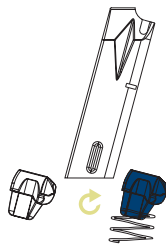

Replace it with the DIGITALCOUNTER follower

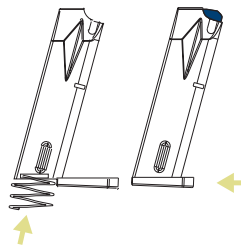

The system is ready to use

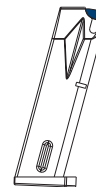

## MAGAZINE CALIBRATION Use only Beretta original magazines.

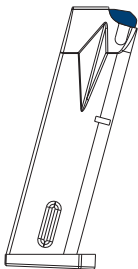

CALIBRATION IS ONLY REQUIRED IF COUNT SEQUENCE IS INCORRECT.

### 1. ENTERING IN CALIBRATION MODE

Pushing counter button (left/right) and reset button (inside grip).

### 2. MAGAZINE

Load 15 cartridges in the magazine.

### 3. GUN

Load a cartridge in the chamber.

### 4. FIRE THE GUN

Shoot holding check button, keeping an interval of 2 seconds between shots.

### 5. EXITING CALIBRATION MODE

Automatically after last shot.

After 15 seconds timeout counting from step 1. By pressing counter button until display shows 0.

## KNOW YOUR DIGITAL COUNTER

### WARNING

Always make sure your firearm is unloaded, no rounds in the chamber and pointed in a safe direction before you disassemble and work on it.

DISPLAY INDICATOR

COUNTER BUTTON  
(LEFT/RIGHT)

RESET BUTTON  
(INSIDE GRIP)

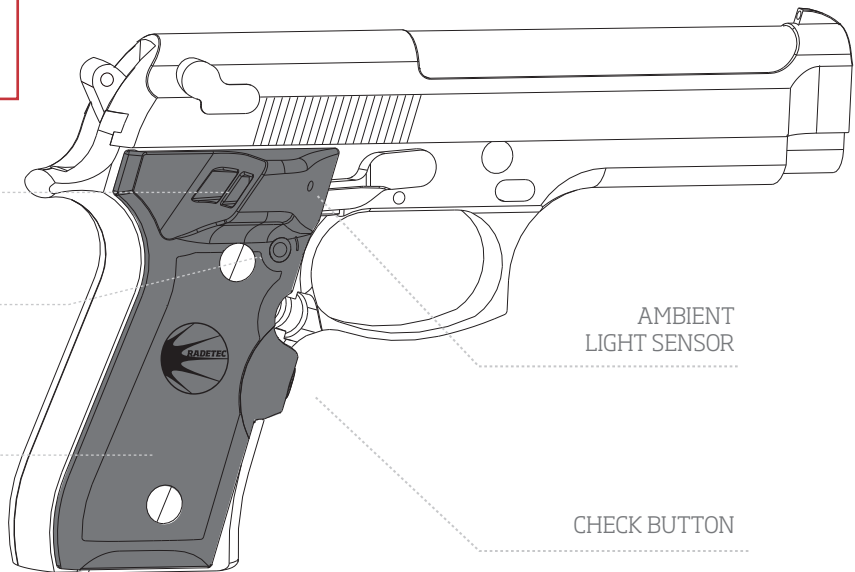

AMBIENT  
LIGHT SENSOR

CHECK BUTTON

## DISPLAY ACTIVATION EVENTS

### ACTIVATION

- Firing the gun.
- Pressing the check button.
- Pressing counter buttons to show the total number of shots fired.



### COUNTER BUTTON

Press these buttons on both sides of the grip to show the accumulated number of shots fired.

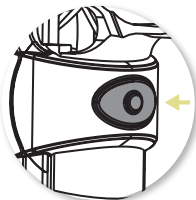

Push the check button to know the number\*\* of cartridges in the magazine.

Display intensity is automatically adjusted depending on ambient light.

### DISPLAY EXAMPLE

### WARNING

This device DOES NOT count rounds in the chamber and DOES NOT show if there is a round in the chamber. Always make sure your firearm is unloaded and with no round in the chamber.

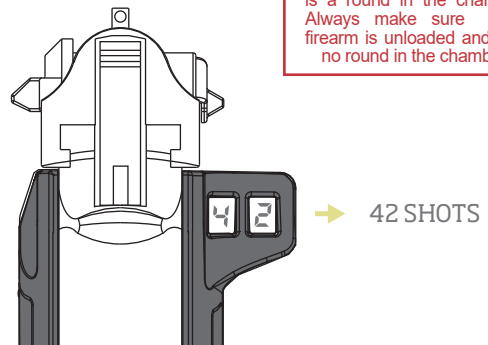

Reset shot counter: push reset button.